

# ACCESS 1000

Industrial Remote Control System for Overhead Doors/Gates



## Access 1000

### Features & Benefits

- For use in facilities with up to 1,000 industrial overhead doors or gates
- Optional powered forklift mount for efficiency and safety
- Robust and user friendly system ideal for most manufacturing or warehouse operations
- 900 MHz frequency, 2-way digital radio technology
- System secured utilizing 16.7 million unique address codes
- Receiver equipped with a detachable memory card for business critical applications using a large base of transmitters
- Weather resistant, IP65 rated



**CONTROL CHIEF**  
WIRELESS SOLUTIONS

# ACCESS 1000

## Technical Specifications

### Overall Specifications

Operating frequency:	926.5 MHz
Power output:	< 5 mW
Transmission principle:	GMSK, TDMA
Operating temperature:	-13°F - 131°F (-25°C - +55°C)
Storage temperature:	-40°F - 185°F (-40°C - +85°C)
<b>Receiver specifications:</b>	
Enclosure rating:	IP65
Power supply:	115 VAC 60 Hz 15 mA, 4AT fuse.
Max switching capacity of relays:	2A/250VAC
Total load on all relays:	4A/250VAC (not exceeding 2A on any single relay)
Relay- type	SPDT
Dimensions:	135 x120 x 50 mm
Weight:	450g
Screw size:	TX20
<b>Transmitter Specifications:</b>	
Enclosure rating:	IP67
Dimensions:	5.3" x 4.7" x 1.9" (120x75x30 mm)
Weight:	.4 lbs (200g)
Battery type:	(2) AA Alkaline batteries
Screw size:	PH2

### Receiver Mounting Dimensions

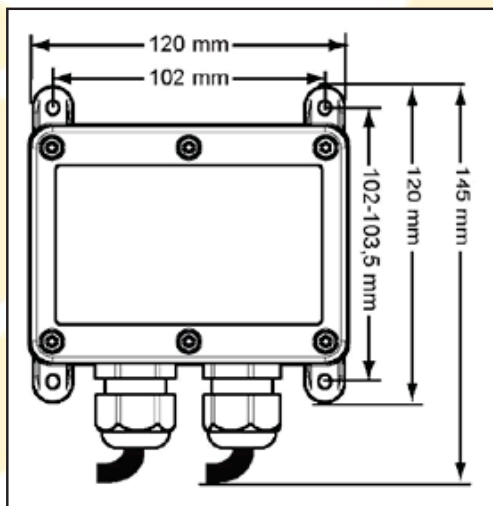

### Wiring Diagram

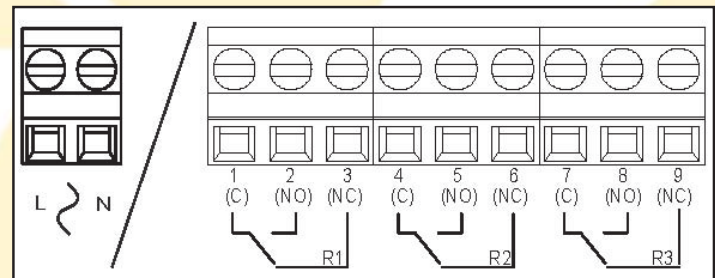

Wiring diagrams for reference only - not for installation

